

TYPE SU-56

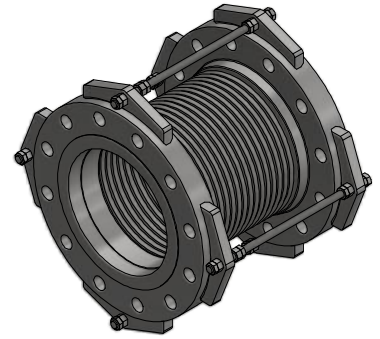
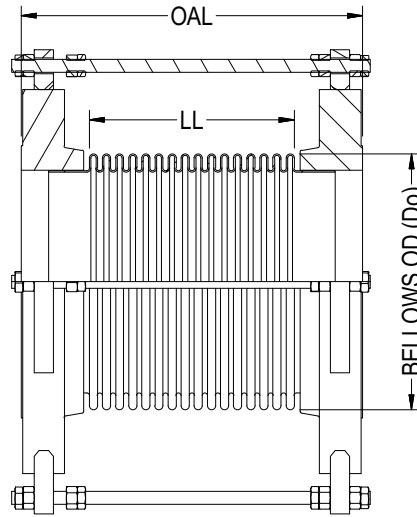

ISOMETRIC VIEW

PIPE SIZE	BELLOWS OD (Do)	LIVE LENGTH (LL)	OVERALL LENGTH (OAL)
1	1.63	3.75	6.00
1	1.60	5.76	8.00
1.25	2.05	3.73	6.00
1.25	2.00	5.73	8.00
1.5	2.30	3.46	6.00
1.5	2.30	5.43	8.00
2	2.95	3.19	6.00
2	2.89	5.23	8.00
2.5	3.50	2.84	6.00
2.5	3.50	4.84	8.00
3	4.13	4.43	6.00
3	4.30	2.49	8.00
3.5	4.90	2.29	6.00
3.5	4.88	4.25	8.00
4	5.50	2.02	6.00
4	5.50	8.04	12.00
4	5.50	19.94	24.00
5	6.50	7.80	12.00
5	6.50	19.74	24.00
6	7.60	7.67	12.00
6	7.60	19.62	24.00
8	10.00	2.66	8.00
8	10.00	6.94	12.00

PIPE SIZE	BELLOWS OD (Do)	LIVE LENGTH (LL)	OVERALL LENGTH (OAL)
8	9.80	18.66	24.00
10	11.90	2.45	8.00
10	12.00	6.57	12.00
10	12.00	18.45	24.00
12	13.90	2.02	8.00
12	13.90	6.10	12.00
12	14.25	17.89	24.00
14	15.50	5.78	12.00
14	15.50	17.67	24.00
16	17.50	11.19	18.00
16	17.50	17.23	24.00
18	19.50	4.77	12.00
18	19.25	10.80	18.00
18	19.50	16.77	24.00
20	21.50	4.35	12.00
20	21.65	10.28	18.00
20	21.65	16.28	24.00
22	23.80	3.96	12.00
22	23.70	9.42	18.00
22	23.70	14.94	24.00
24	25.90	3.45	12.00
24	25.60	9.32	18.00
24	25.65	15.33	24.00

NOTES:

1. FLANGES ARE OF 300# RFSO. (ANSI B16.5 BOLT PATTERN)
2. FLANGE MATERIAL: ASTM A-105. FOR OTHER OPTIONAL MATERIAL PLEASE CONTACT BSI.
3. OAL IS BASED ON LIVE LENGTH. FOR OTHER OPTIONAL LENGTH PLEASE PROVIDE THEM IN THE SPECIFICATION SHEET.
4. BELLOWS MATERIAL: ASTM A-240 GRADE 304. OTHER MATERIALS (STAINLESS STEEL, NICKEL ALLOYS ETC.) ARE AVAILABLE ON REQUEST.
5. AVAILABLE IN 1 PLY, 2 PLY (STD) OR 3 PLY DESIGNS.
6. SPECIFY DESIGN/OPERATING TEMPERATURE & PRESSURE IN PAGE 2.
7. FOR MOVEMENTS AND LIFE CYCLE REFER TO BELLOWS CATALOG OR CONTACT BSI ENGINEERING.

				 Bellows Systems		BELLOWS SYSTEMS, INC. Houston, TX www.bellows-systems.com	
						SINGLE EXPANSION JOINT STD. TYPE SU-56 W/ 300# RFSO FLG & CONTROL RODS	
E	UPDATED TYPE NO.	11/8/2023	UG	CAGE CODE: 22727		DRAWING NUMBER: 130-CAT-0056	SHEET#: 1 OF 1
D	UPDATED NOTES	09/13/2023	UG	DRAWN BY: U GULATI		SCALE: AS SHOWN	REV. E
REV.	DESCRIPTION	DATE:	BY:	CHKD:	APPD:	DRAWING NUMBER: 130-CAT-0056	SHEET#: 1 OF 1
THIS DRAWING AND ALL OF THE INFORMATION HEREIN ARE THE SOLE PROPERTY OF BELLOWS SYSTEMS, INC. AND MAY NOT BE REPRODUCED OR DISTRIBUTED WITHOUT THE EXPRESS WRITTEN CONSENT OF BELLOWS SYSTEMS, INC. (BSI).				SHEET SIZE: 8.5" x 11"		DATE: 03/13/2023	

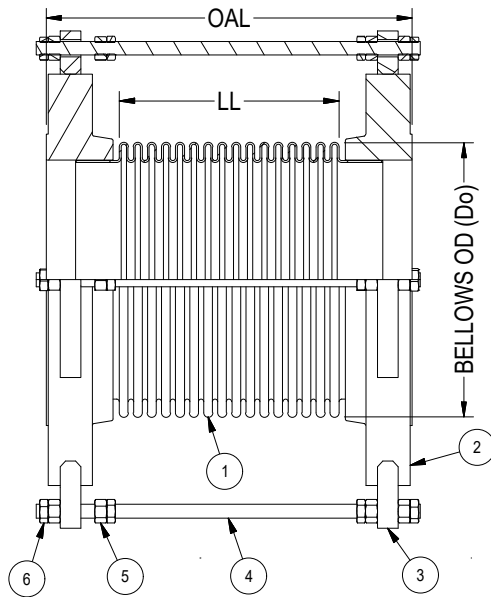

		1	2	3	4
DIM.:	PIPE/ NOMINAL SIZE:				
	OVERALL LENGTH (OAL):				
DESIGN:	PRESSURE:				
	TEMPERATURE:				
MOV. & LIFE CYLS:	AXIAL COMPRESSION:				
	AXIAL EXPANSION:				
	LATERAL:				
	ANGULAR:				
	NO. OF CYCLES:				
MATL'S:	① BELLOWS:				
	② FLANGE:				
	③ LUG:				
	④ CONTROL ROD:				
	⑤ HEX NUTS:				
	⑥ HEX JAM NUTS:				
DESIGN CODES/STANDARDS: (EJMA/ ASME SECT VII DIV I/ ASME B 31.1/ ASME B 31.3)					
APPLICATION NOTES:					
QUANTITY:					

OPTIONAL FEATURES:

1. WITHOUT FLOW LINER (SEE TYPE-06).
2. FLOW LINER (SEE TYPE-26).
3. EXTERNAL COVER.

 Bellows Systems						BELLOWS SYSTEMS, INC. Houston, TX www.bellows-systems.com	
						SINGLE EXPANSION JOINT TYPE SU-56 SPECIFICATION SHEET	
REV.	DESCRIPTION	DATE:	BY:	CHKD:	APPD:	CAGE CODE: 22727	
E	UPDATED TYPE NO.	11/8/2023	UG			DRAWING NUMBER: 130-CAT-0056	
D	UPDATED NOTES	09/13/2023	UG			SHEET#: 2 OF 2	
THIS DRAWING AND ALL OF THE INFORMATION HEREIN ARE THE SOLE PROPERTY OF BELLOWS SYSTEMS, INC. AND MAY NOT BE REPRODUCED OR DISTRIBUTED WITHOUT THE EXPRESS WRITTEN CONSENT OF BELLOWS SYSTEMS, INC. (BSI).						SHEET SIZE: 8.5" x 11"	
DRAWN BY: U GULATI						DATE: 03/13/2023	
SCALE: AS SHOWN						REV. E	