

# TYPE SU-01

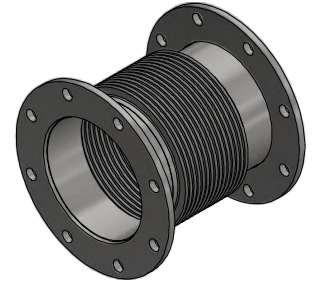
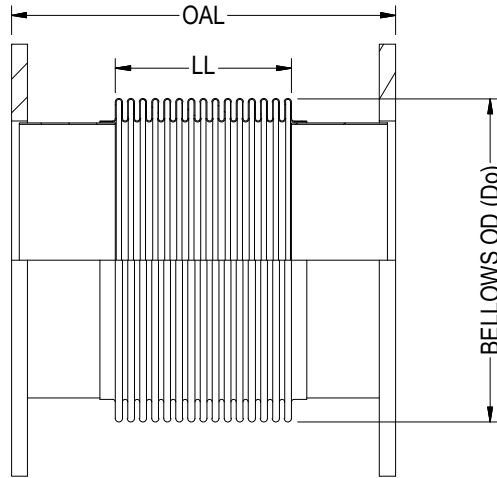

ISOMETRIC VIEW

| PIPE SIZE | BELLOWS OD (Do) | LIVE LENGTH (LL) | OVERALL LENGTH (OAL) |
|-----------|-----------------|------------------|----------------------|
| 2         | 3.10            | 2.00             | 6.00                 |
| 2         | 3.10            | 6.00             | 12.00                |
| 2-1/2     | 3.70            | 2.00             | 6.00                 |
| 2-1/2     | 3.70            | 6.00             | 12.00                |
| 3         | 4.40            | 2.00             | 6.00                 |
| 3         | 4.40            | 6.00             | 12.00                |
| 4         | 5.36            | 2.50             | 6.00                 |
| 4         | 5.36            | 5.50             | 12.00                |
| 4         | 5.15            | 9.00             | 18.00                |
| 5         | 6.70            | 3.00             | 8.00                 |
| 5         | 6.55            | 5.50             | 12.00                |
| 6         | 7.70            | 3.00             | 8.00                 |
| 6         | 7.63            | 5.50             | 12.00                |
| 8         | 10.10           | 4.13             | 8.00                 |
| 8         | 10.10           | 5.50             | 12.00                |
| 10        | 12.00           | 2.00             | 4.00                 |
| 10        | 12.10           | 4.00             | 8.00                 |
| 10        | 12.00           | 5.50             | 12.00                |
| 12        | 14.80           | 6.00             | 12.00                |
| 12        | 14.00           | 8.00             | 18.00                |
| 12        | 14.30           | 13.50            | 23.00                |
| 14        | 16.30           | 1.25             | 4.50                 |
| 14        | 16.00           | 4.50             | 12.00                |

| PIPE SIZE | BELLOWS OD (Do) | LIVE LENGTH (LL) | OVERALL LENGTH (OAL) |
|-----------|-----------------|------------------|----------------------|
| 14        | 15.75           | 13.00            | 23.00                |
| 16        | 17.75           | 8.00             | 16.00                |
| 16        | 17.75           | 13.50            | 23.00                |
| 18        | 20.20           | 4.00             | 12.00                |
| 18        | 20.20           | 10.00            | 18.00                |
| 18        | 20.20           | 13.00            | 23.00                |
| 20        | 22.00           | 4.00             | 6.00                 |
| 20        | 22.25           | 4.50             | 12.00                |
| 20        | 21.91           | 9.00             | 18.00                |
| 20        | 21.75           | 13.50            | 23.00                |
| 24        | 25.90           | 4.50             | 12.00                |
| 24        | 26.00           | 12.00            | 18.00                |
| 24        | 26.00           | 13.00            | 22.00                |
| 24        | 25.75           | 20.00            | 36.00                |
| 26        | 27.75           | 14.00            | 22.00                |
| 26        | 27.75           | 18.00            | 30.00                |
| 28        | 30.70           | 12.50            | 24.00                |
| 30        | 31.75           | 4.00             | 10.00                |
| 30        | 32.00           | 8.00             | 16.00                |
| 30        | 31.75           | 18.00            | 29.00                |
| 36        | 38.25           | 2.50             | 7.00                 |
| 36        | 38.40           | 6.00             | 12.00                |
| 36        | 37.97           | 9.00             | 17.00                |

**NOTES:**

1. FLANGES ARE OF 150# LW PLT-1/2" THK. (ANSI B16.5 BOLT PATTERN)
2. FLANGE MATERIAL: ASTM A-36. FOR OTHER OPTIONAL MATERIAL PLEASE CONTACT BSI.
3. OAL IS BASED ON LIVE LENGTH. FOR OTHER OPTIONAL LENGTH PLEASE PROVIDE THEM IN THE SPECIFICATION SHEET.
4. BELLOWS MATERIAL: ASTM A-240 GRADE 321. OTHER MATERIALS (STAINLESS STEEL, NICKEL ALLOYS ETC.) ARE AVAILABLE ON REQUEST.
5. AVAILABLE IN 1 PLY, 2 PLY (STD) OR 3 PLY DESIGNS.
6. SPECIFY DESIGN/OPERATING PRESSURE & TEMPERATURE IN PAGE 2.
7. FOR MOVEMENTS AND LIFE CYCLE REFER TO BELLOWS CATALOG OR CONTACT BSI ENGINEERING.

|  |                  |            |     |  |                       |   |                          |
|--|------------------|------------|-----|--|-----------------------|---|--------------------------|
|  |                  |            |     |  <b>Bellows Systems</b> |                       | BELLOWS SYSTEMS, INC.<br>Houston, TX<br>www.bellows-systems.com |                          |
|  |                  |            |     |  |                       | SINGLE EXPANSION JOINT<br>STD. TYPE SU-01 W/ 150# LW PLT FLG    |                          |
| REV.   | DESCRIPTION      | DATE:      | BY: | CHKD:  | APPD:                 | CAGE CODE: 22727  |                          |
| E  | UPDATED TYPE NO. | 11/8/2023  | UG  |  |                       |   |                          |
| D  | UPDATED NOTES    | 09/11/2023 | UG  |  |                       |   |                          |
| THIS DRAWING AND ALL OF THE INFORMATION HEREIN ARE THE SOLE PROPERTY OF BELLOWS SYSTEMS, INC. AND MAY NOT BE REPRODUCED OR DISTRIBUTED WITHOUT THE EXPRESS WRITTEN CONSENT OF BELLOWS SYSTEMS, INC. (BSI). |                  |            |     | SHEET SIZE:<br>8.5" x 11"  | DRAWN BY:<br>U GULATI | DATE:<br>01/13/2023   | SCALE:<br>AS SHOWN       |
|  |                  |            |     |  |                       | DRAWING NUMBER: 130-CAT-0001                                    | SHEET#: 1 OF 2<br>REV. E |

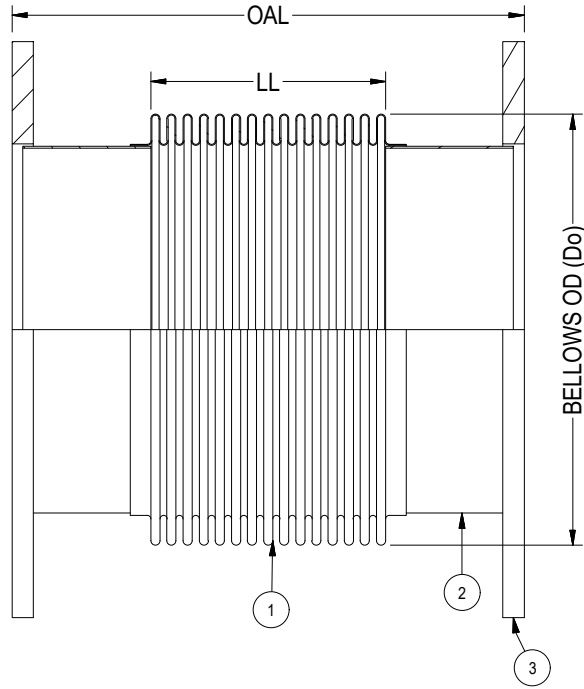

|   |                       | 1 | 2 | 3 | 4 |
|---|-----------------------|---|---|---|---|
| <b>DIM.:</b>  | PIPE/ NOMINAL SIZE:   |   |   |   |   |
|   | OVERALL LENGTH (OAL): |   |   |   |   |
| <b>DESIGN:</b>  | PRESSURE:             |   |   |   |   |
|   | TEMPERATURE:          |   |   |   |   |
| <b>MOV. &amp; LIFE CYLS:</b>  | AXIAL COMPRESSION:    |   |   |   |   |
|   | AXIAL EXPANSION:      |   |   |   |   |
|   | LATERAL:              |   |   |   |   |
|   | ANGULAR:              |   |   |   |   |
|   | NO. OF CYCLES:        |   |   |   |   |
| <b>MATL'S:</b>  | ① BELLOWS:            |   |   |   |   |
|   | ② WELD NECK:          |   |   |   |   |
|   | ③ FLANGE:             |   |   |   |   |
| <b>DESIGN CODES/STANDARDS:</b><br>(EJMA/ ASME SECT VII DIV I/ ASME B 31.1/ ASME B 31.3) |                       |   |   |   |   |
| <b>APPLICATION NOTES:</b>   |                       |   |   |   |   |
| <b>QUANTITY:</b>  |                       |   |   |   |   |

**OPTIONAL FEATURES:**

1. FLOW LINER (SEE TYPE-21).
2. FIXED & FLOATING FLANGE (SEE TYPE-31).
3. CONTROL RODS (SEE TYPE-41).
4. EXTERNAL COVER.

|  |             |                        |                    |                  |                 |   |                              |                |        |
|--|-------------|------------------------|--------------------|------------------|-----------------|---|------------------------------|----------------|--------|
|    |             |                        |                    |                  |                 | <b>BELLOWS SYSTEMS, INC.</b><br>Houston, TX<br><a href="http://www.bellows-systems.com">www.bellows-systems.com</a> |                              |                |        |
|  |             |                        |                    |                  |                 | SINGLE EXPANSION JOINT<br>TYPE SU-01 SPECIFICATION SHEET  |                              |                |        |
| REV.   | DESCRIPTION | DATE:                  | BY:                | CHKD:            | APPD:           | CAGE CODE: 22727  | DRAWING NUMBER: 130-CAT-0001 | SHEET#: 2 OF 2 | REV. E |
| THIS DRAWING AND ALL OF THE INFORMATION HEREIN ARE THE SOLE PROPERTY OF BELLOWS SYSTEMS, INC. AND MAY NOT BE REPRODUCED OR DISTRIBUTED WITHOUT THE EXPRESS WRITTEN CONSENT OF BELLOWS SYSTEMS, INC. (BSI). |             | SHEET SIZE: 8.5" x 11" | DRAWN BY: U GULATI | DATE: 01/13/2023 | SCALE: AS SHOWN |   |                              |                |        |